

(Figure 11)

Spot Shooting

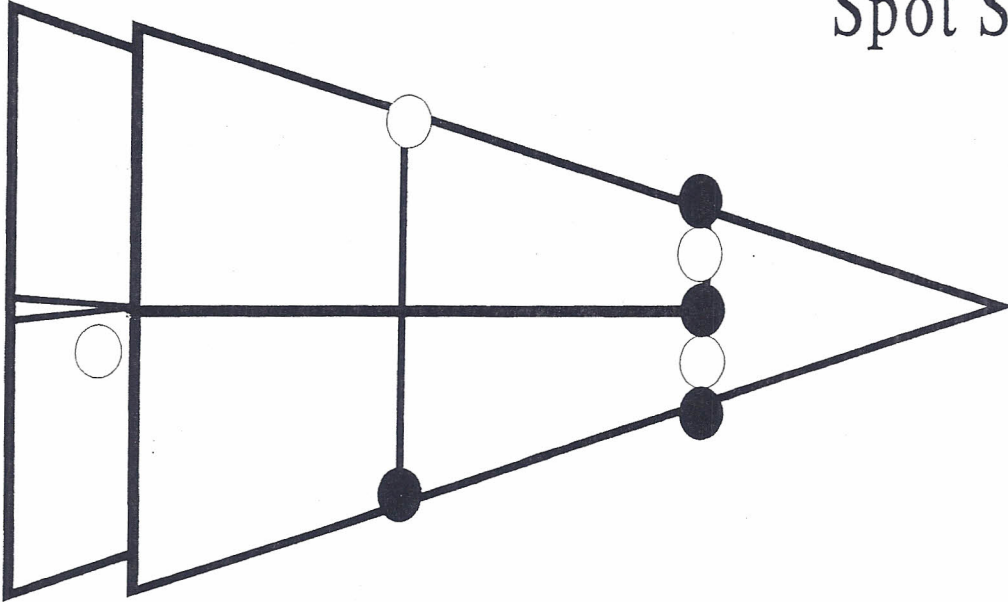

(Figure 12-A)

The Scoring Area

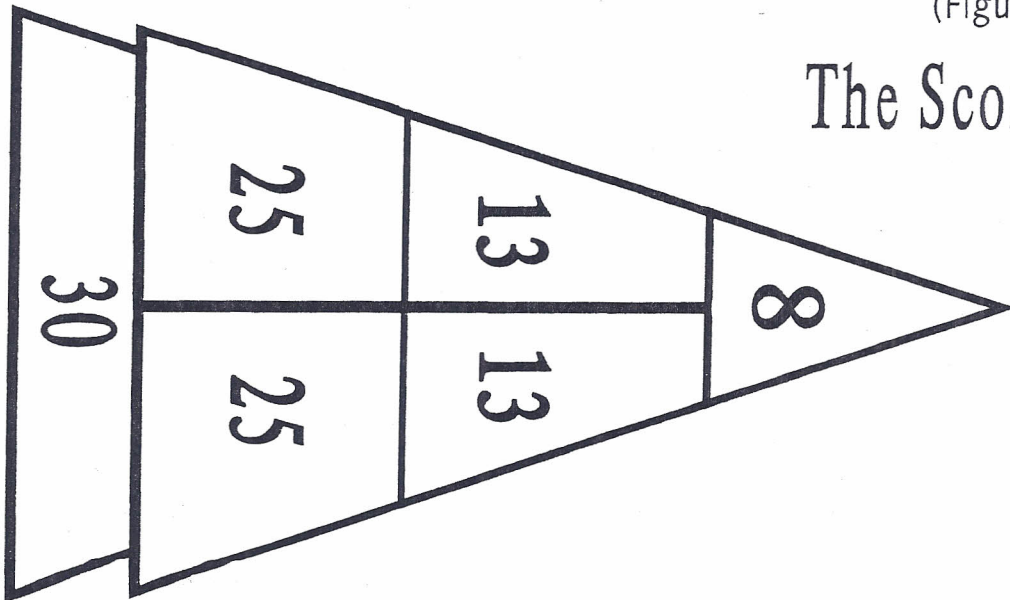

The St. Pete (Figure 12-B)

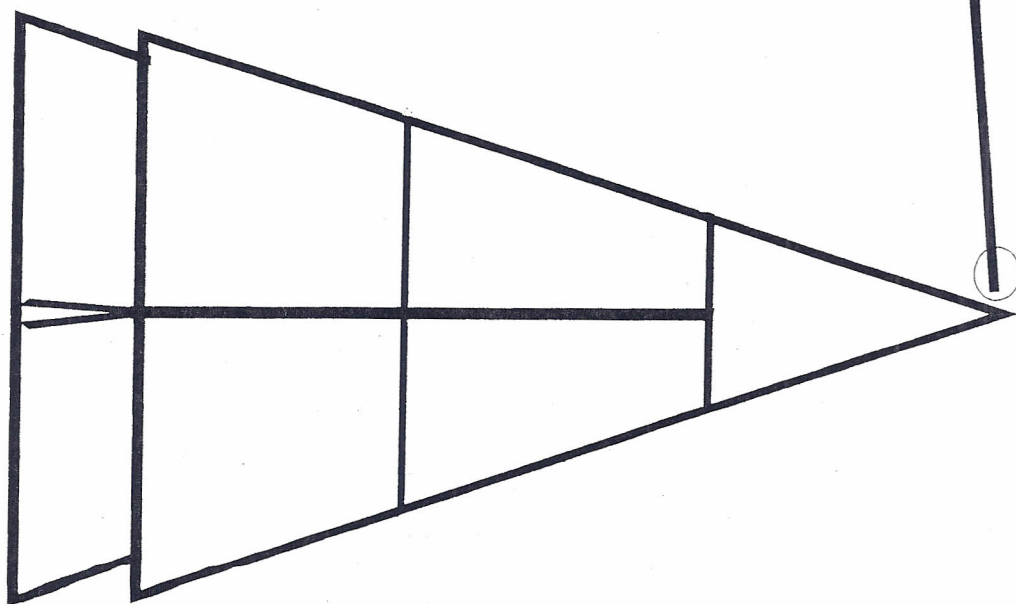
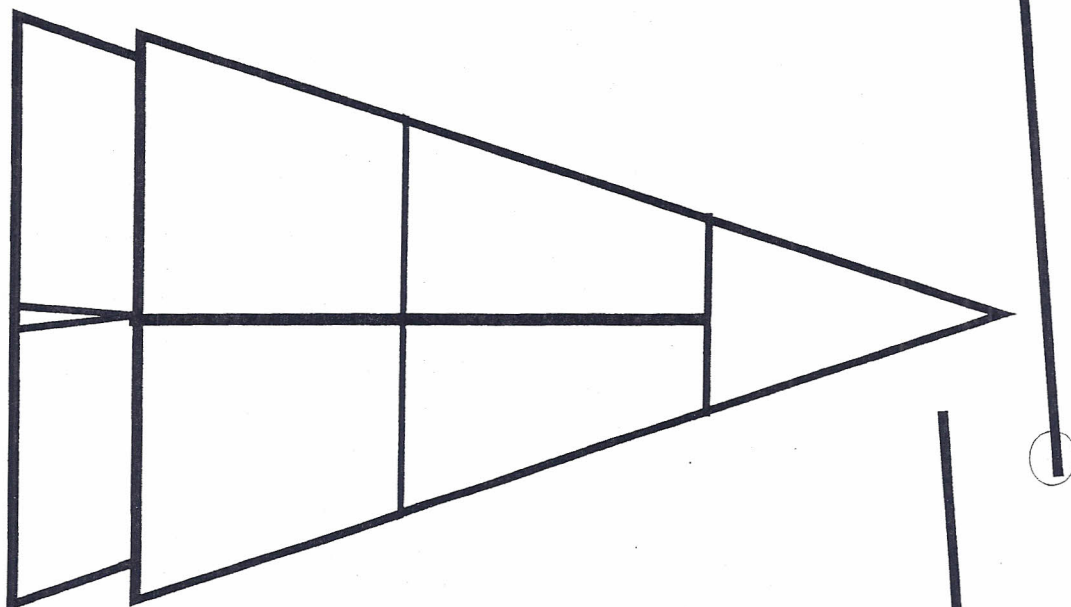

The Tampa

Controlling the 10 Area

(Figure 13)

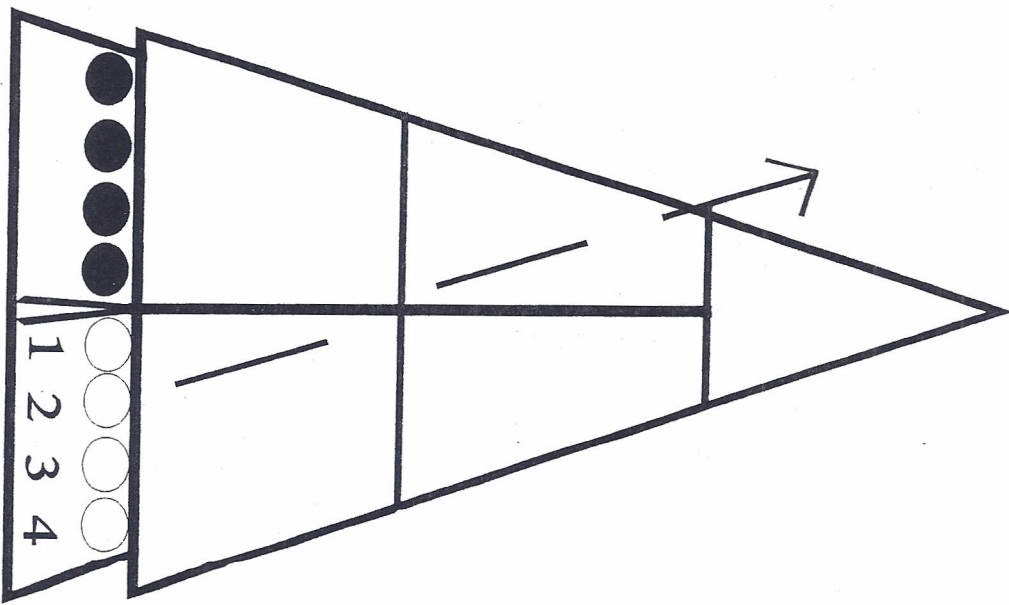
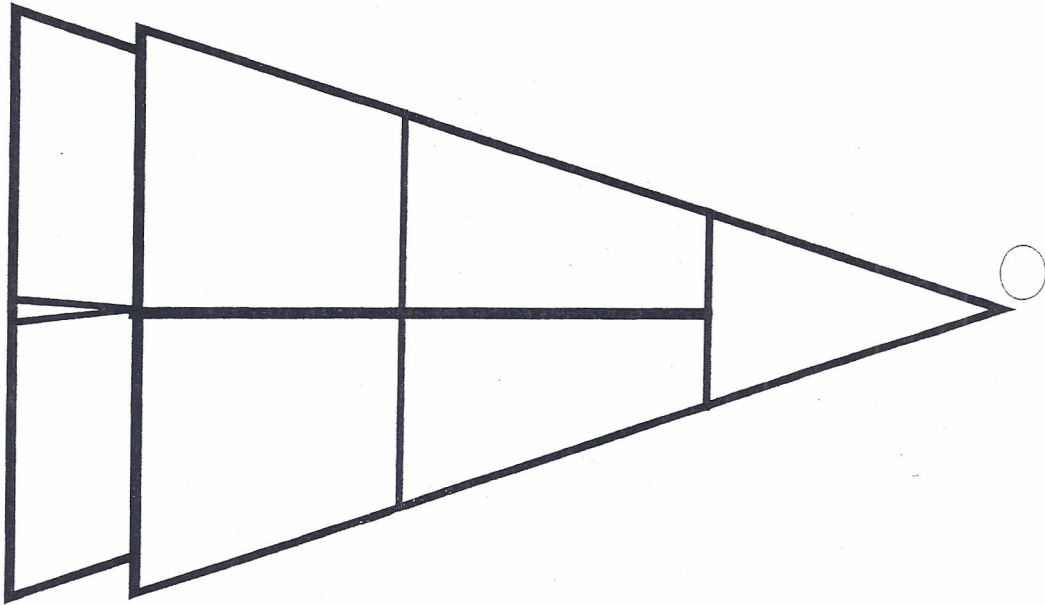

Finding the Line

(Figure 14)

Score Again or Block

(Figure 15)

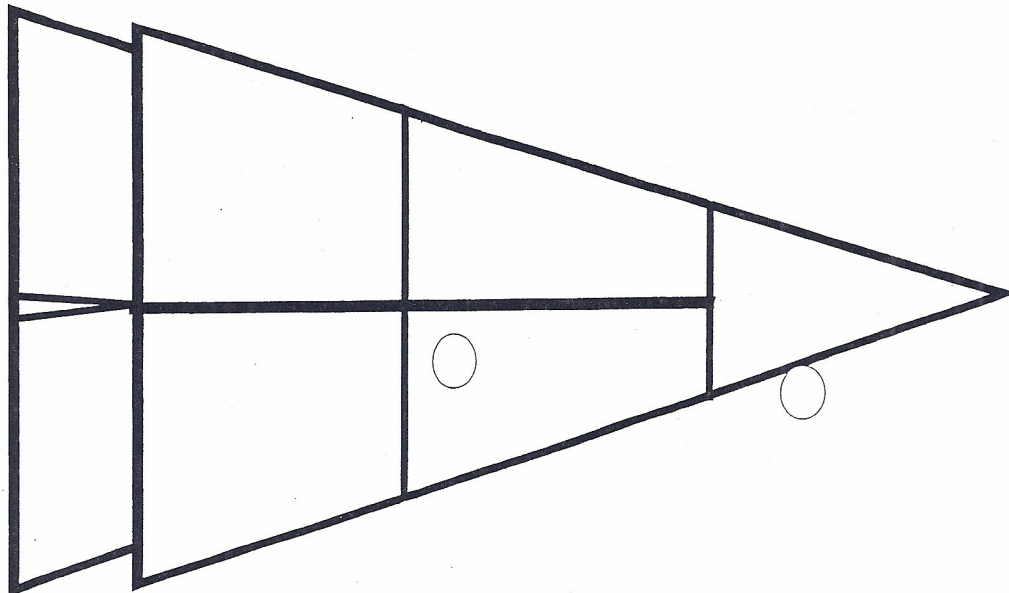

Hammer Shot

(Figure 16)

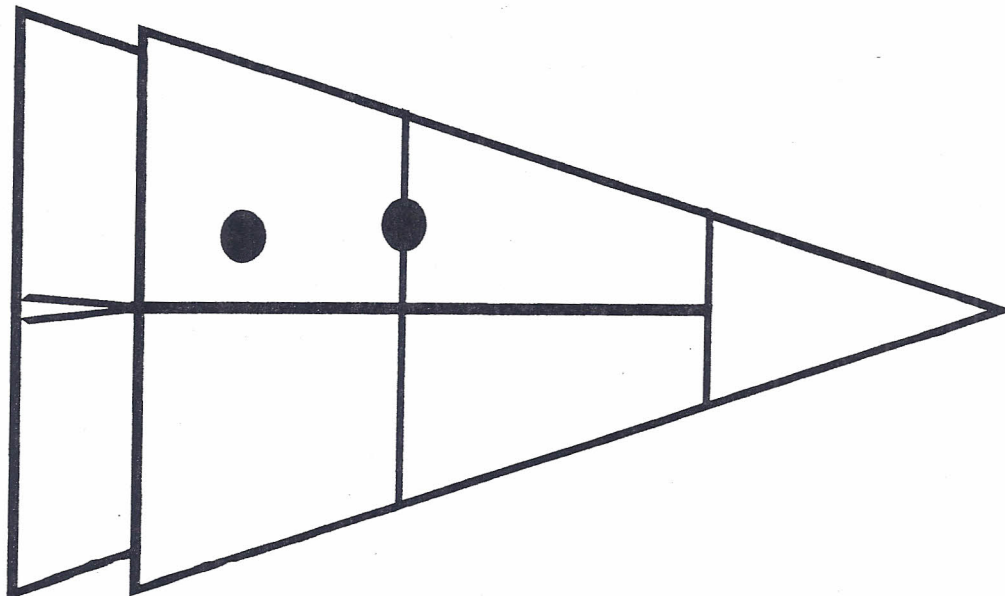
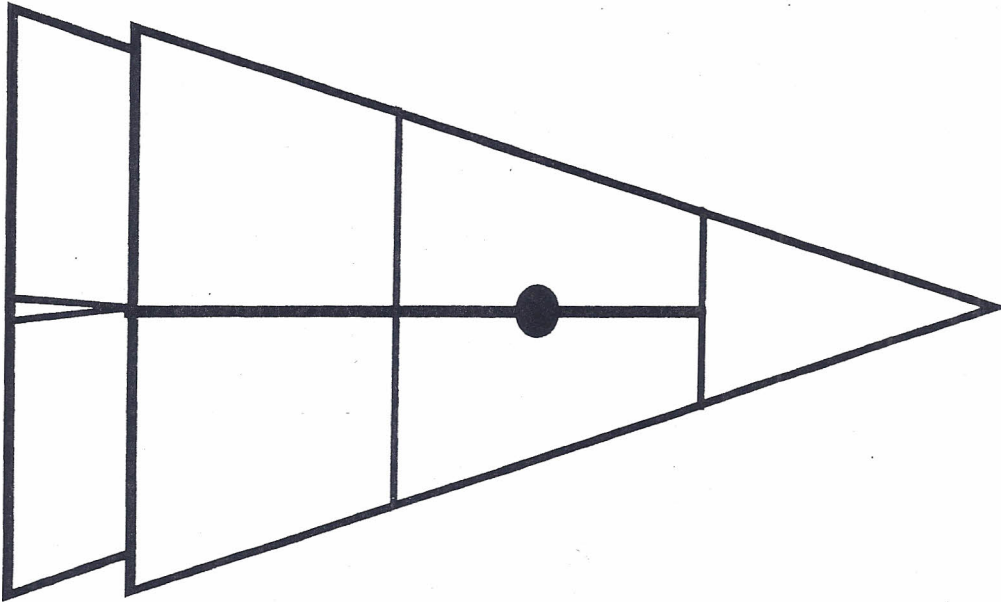

Hammer - Counter Blocked

(Figure 17)

Disc #3 Hide - BEWARE (Figure 18)

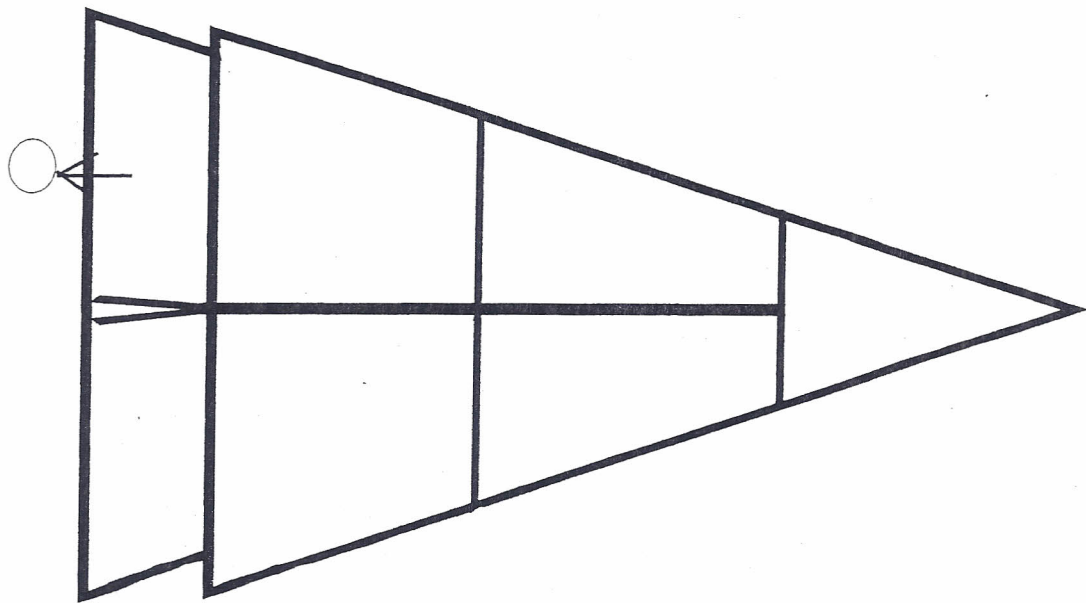
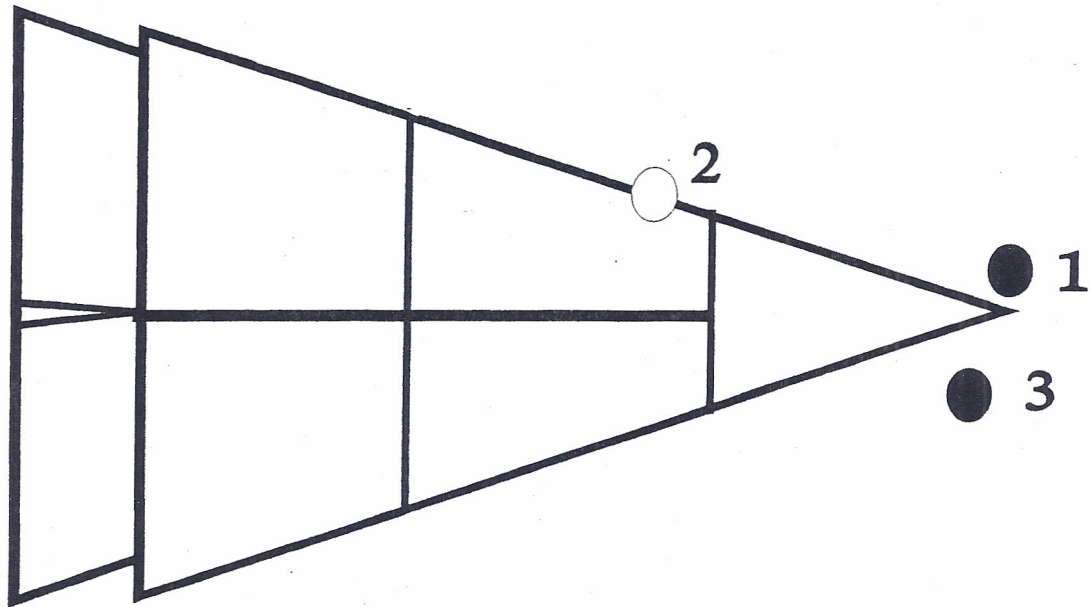

Court Clear/Disc 6 (Figure 19)

Yellow or Black Court (Figure 20)

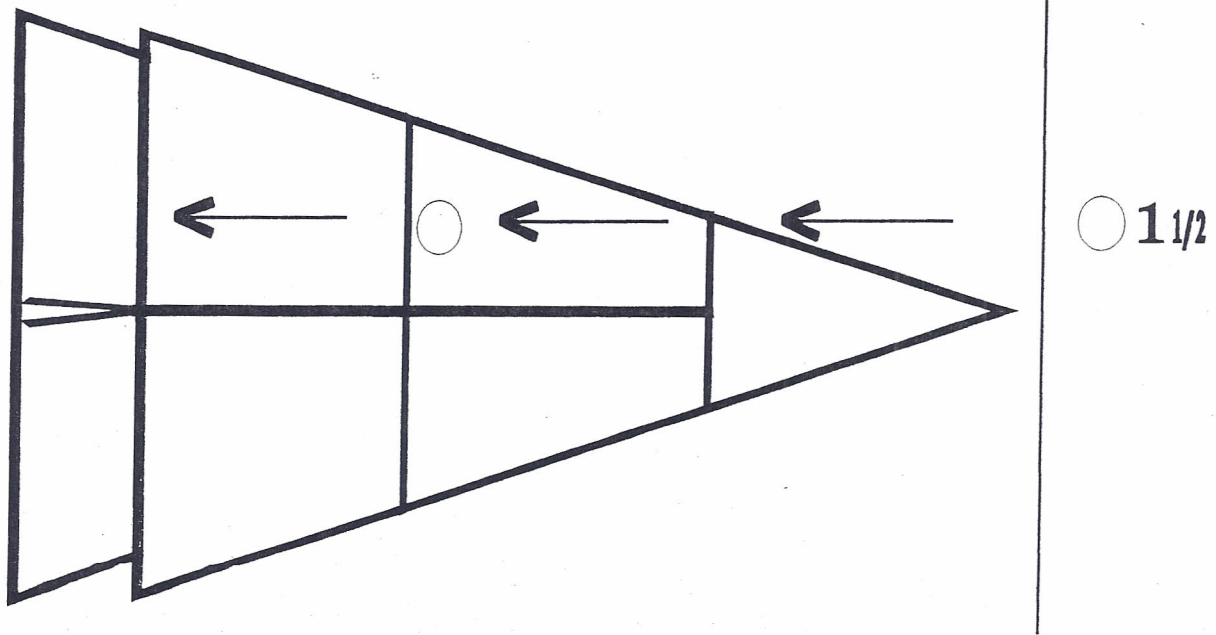
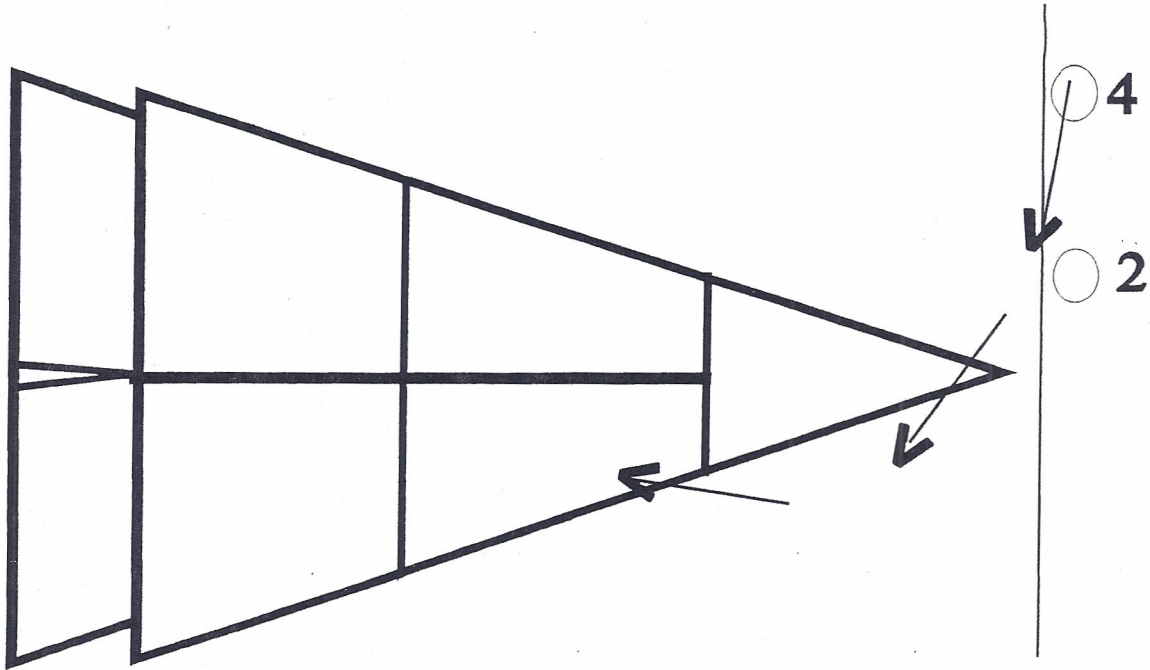

Take Out Speed (Figure 21)

Opponent Disc Near the 10 Before Hammer (Figure 22)

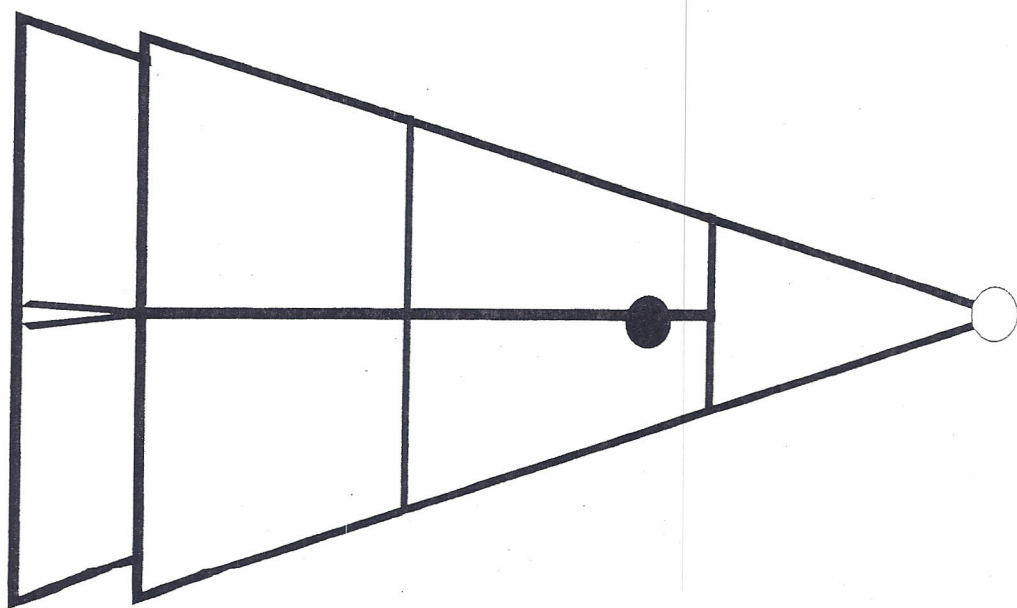
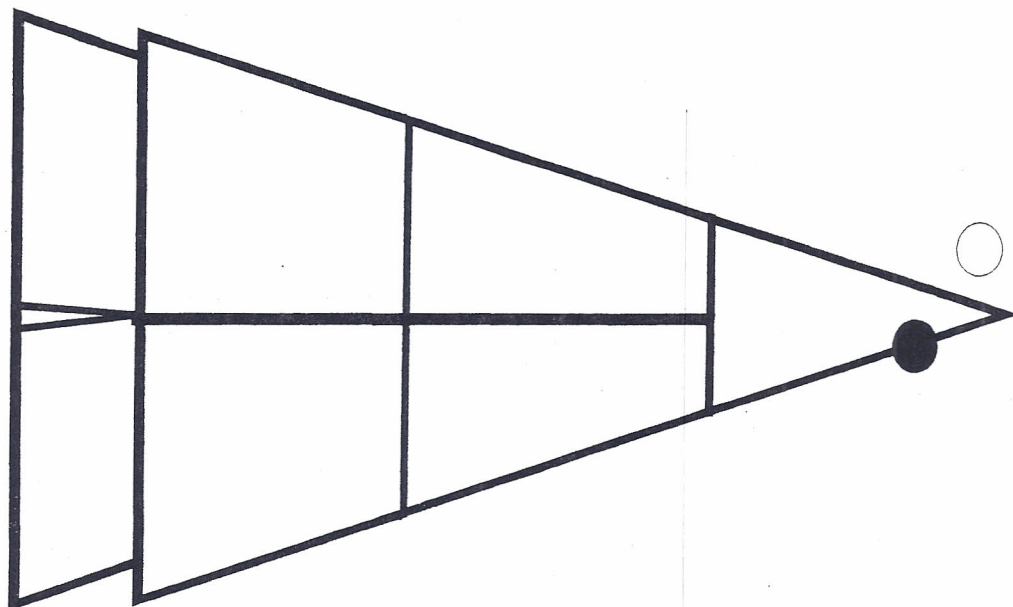

Opponent's Disc on 8 Lines Before Their Hammer

(Figure 23)

The Deep 7 (Figure 24)

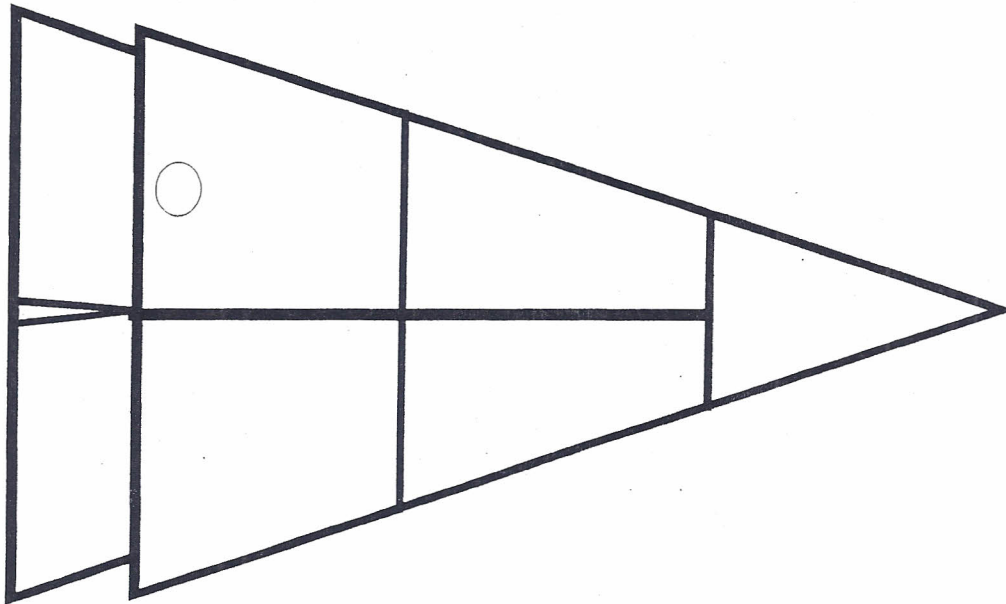

Luck in Shuffleboard (Figure 25)

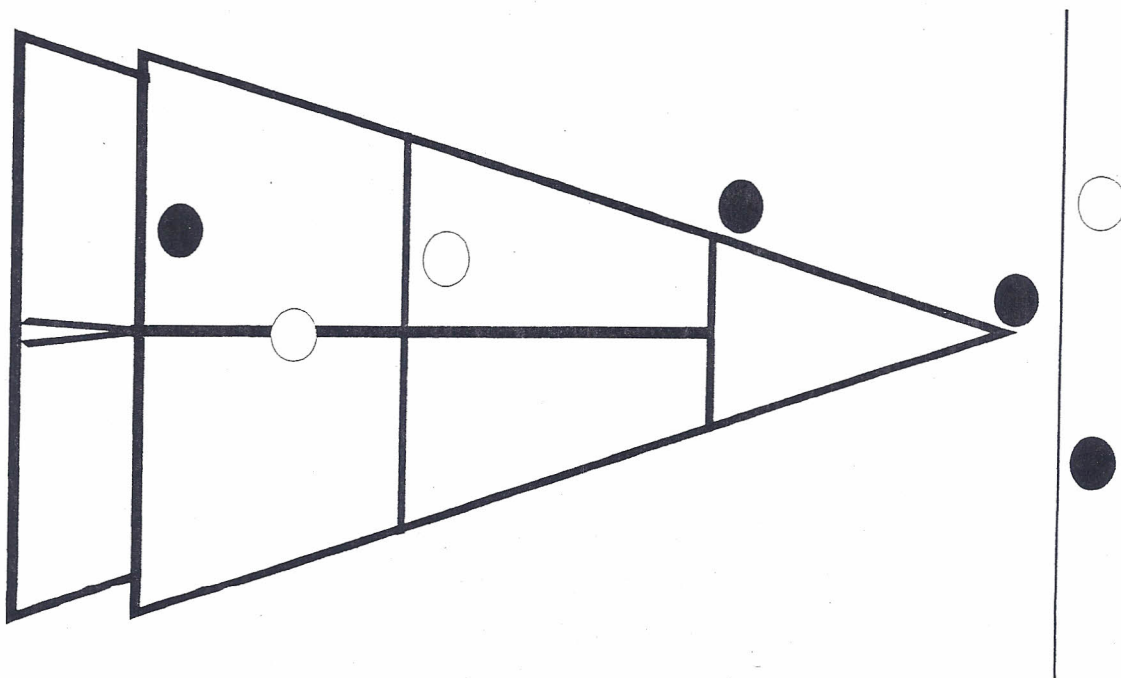

Magic Numbers (Figure 26)

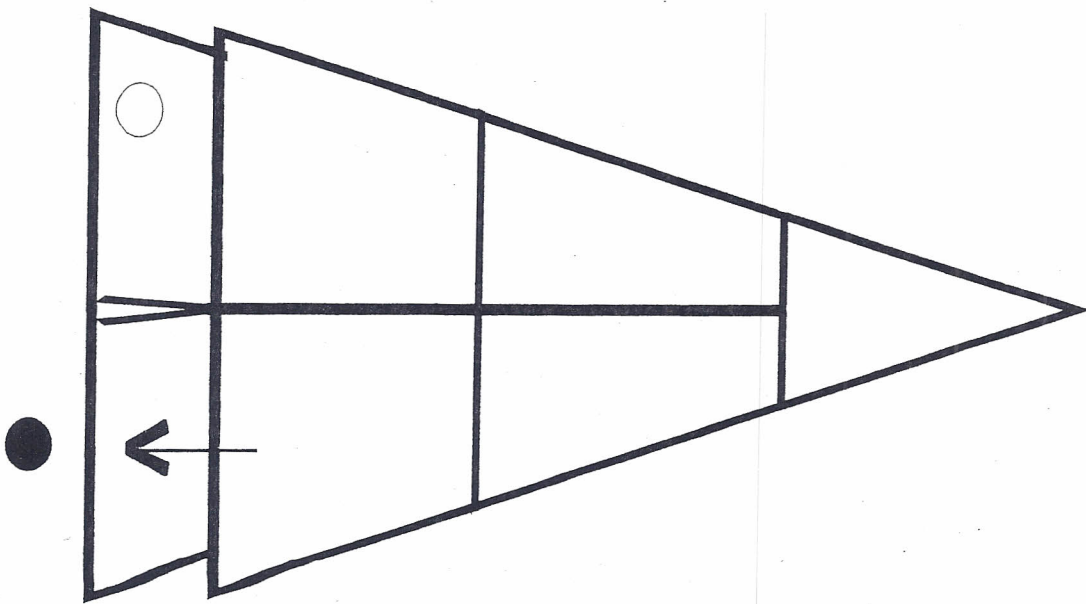
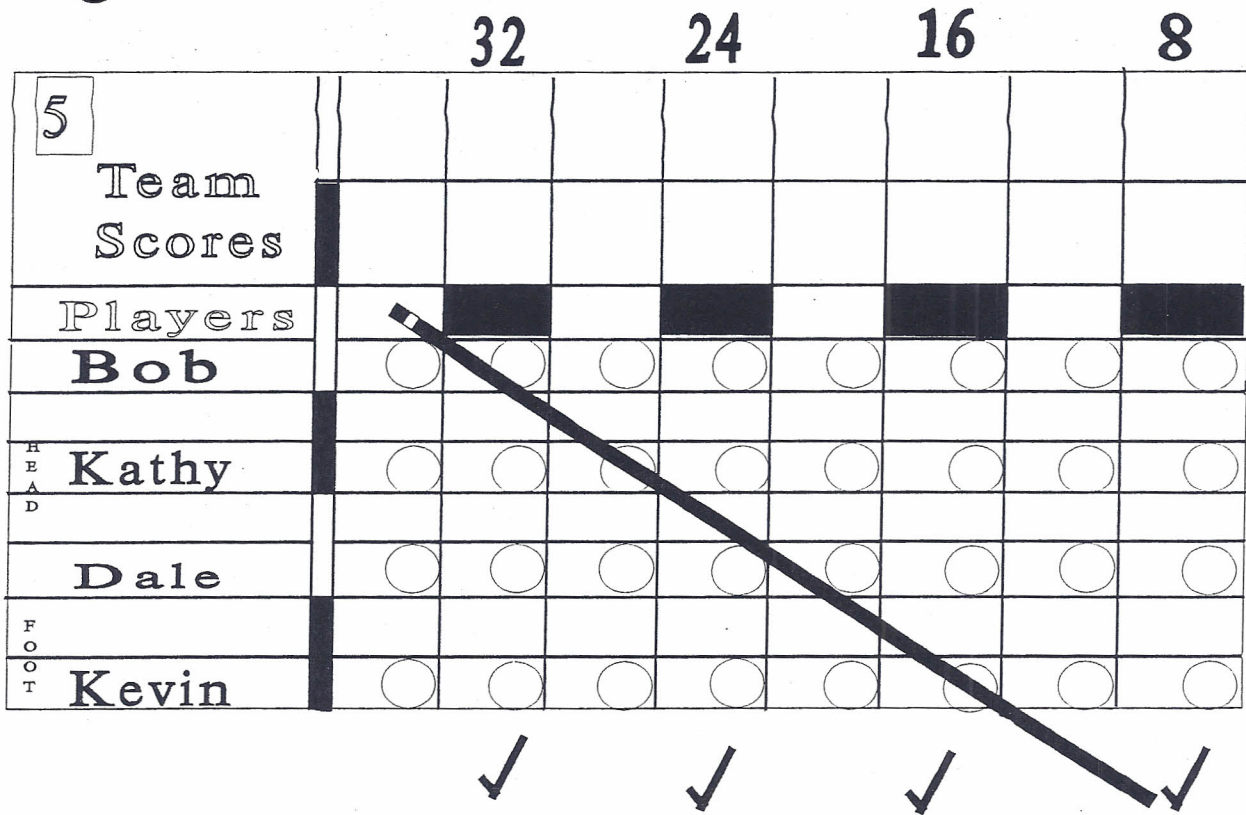

Should We Block Kitchen? (Figure 27)

Should I Knock Off My Disc? (Figure 28)

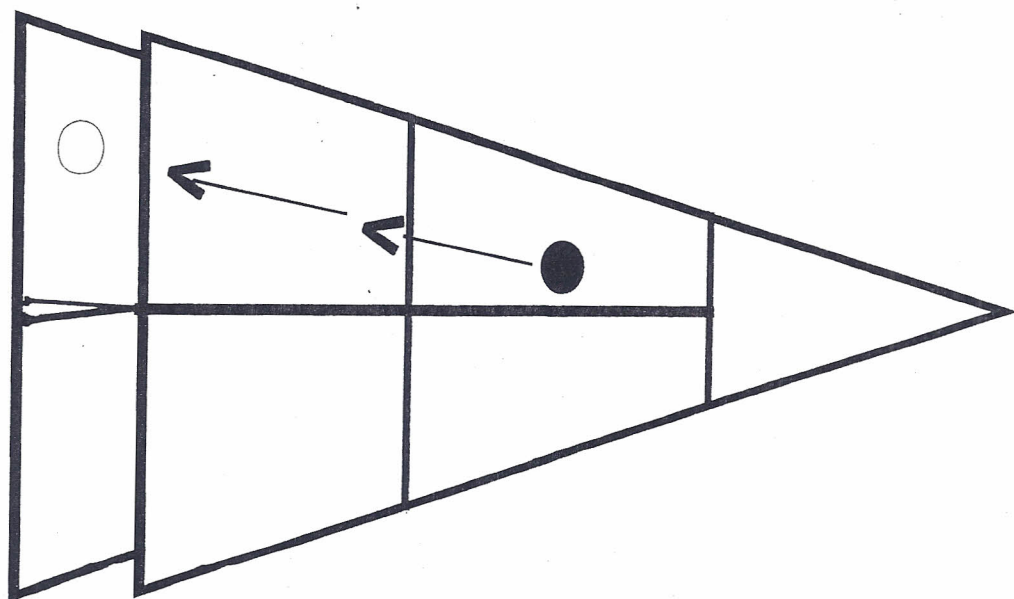
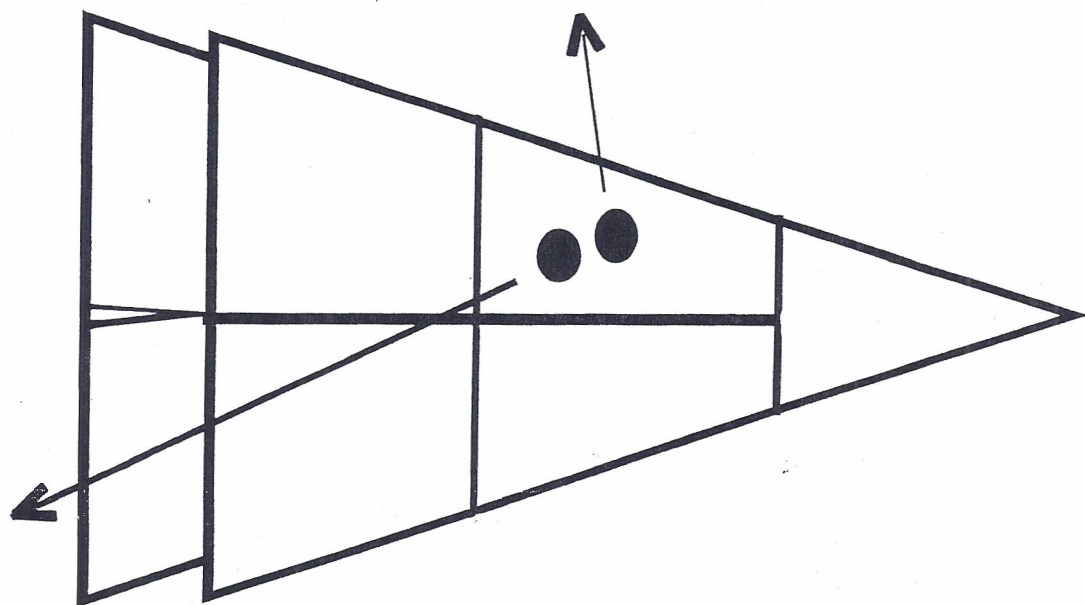

Do I Play Kitchen? (Figure 29)

Blocking Deep 7 with an 8? (Figure 30)

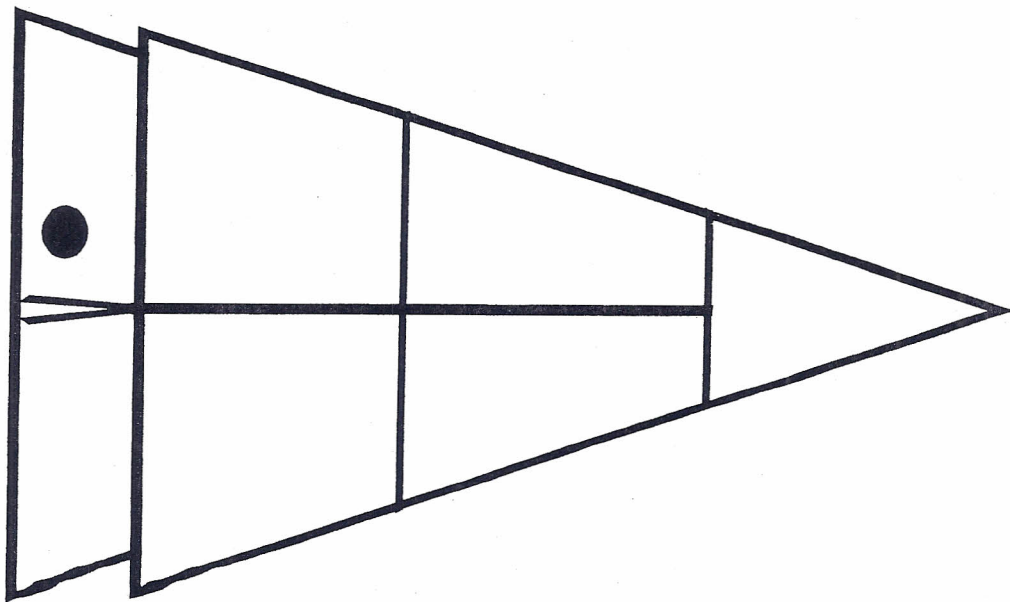
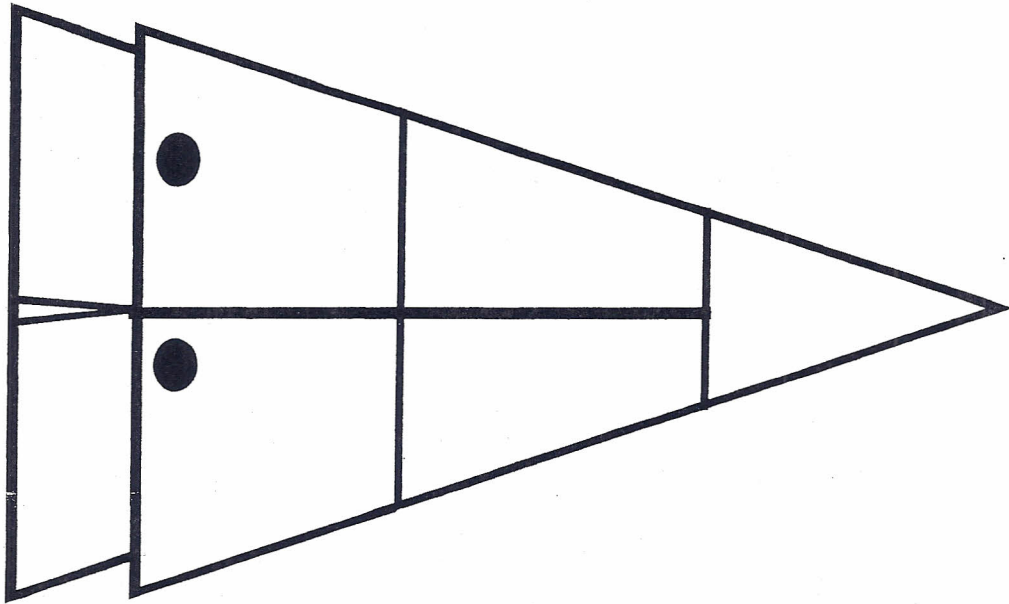

Afraid of Kitchen? (Figure 31)